

Infrared Thermal Imaging Camera

For Passing Through Flame

InfReC R300BP-TF

Through Flame Uncooled Light Weight And Compact

Maintenance-free operation and detecting 3.8μm wavelength band thanks to Japanese-made uncooled infrared detector !

- Maintenance of a cooling mechanism is unnecessary

Making Quick Shot in a harsh environments by a infrared camera with outstanding mobility and operability in the field.

- Lightweight and compact body weighing only 1.5kg. ※1
- A rotational LCD monitor enables to capture images at various angles.
- Thermal movie images can be recorded on SD card.

Folding protection shield included as standard

- Imaging is possible while assuring the safety of the operator from intensive radiant heat

Combination with relay lens※2 inserted in the furnace is available

- A wide field of view (Up to 100°) is available through a furnace wall window.

※1 : It is including a battery pack and excluding protection shield
 ※2 : Relay lens is custom made for customer

Sharp Image Passing Through Flame inside of Coal and Oil Refinery Furnaces!

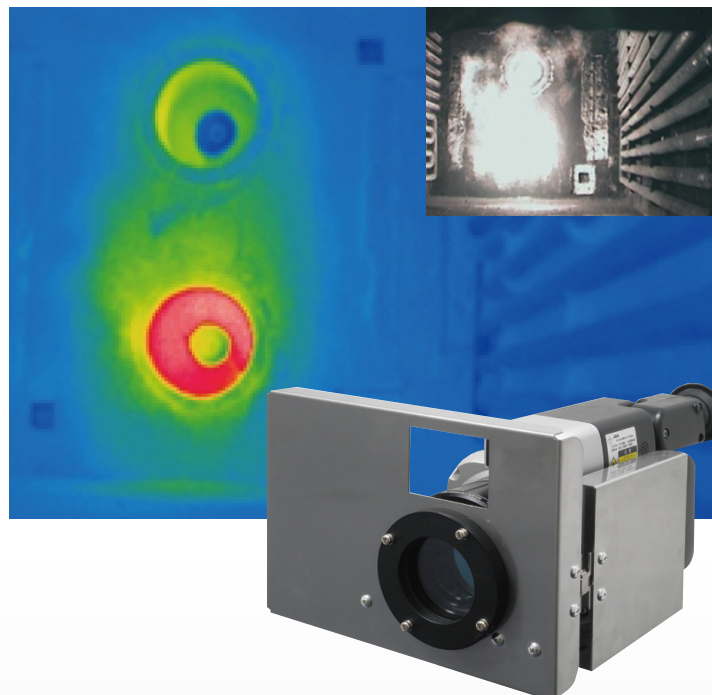

The flame is eliminated by the “Japanese-made” infrared detector with a passing-flame filter with outstanding sensitivity at 3.8μm wavelength band

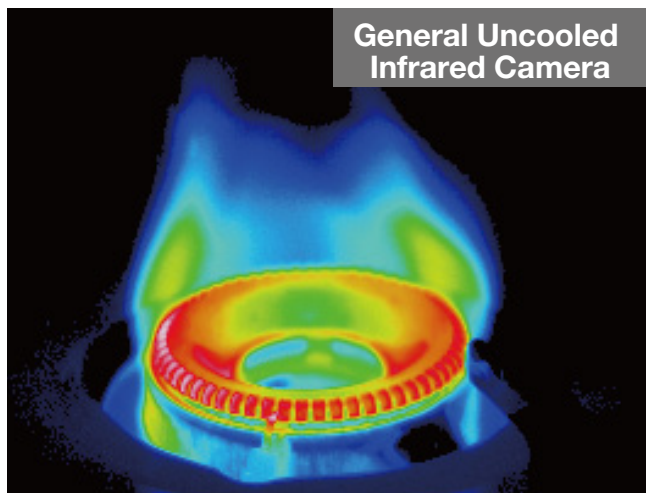

General Uncooled Infrared Camera

In the wavelength range (8 to 14μm) of the general uncooled infrared detector, the influence of the flame is clearly present.

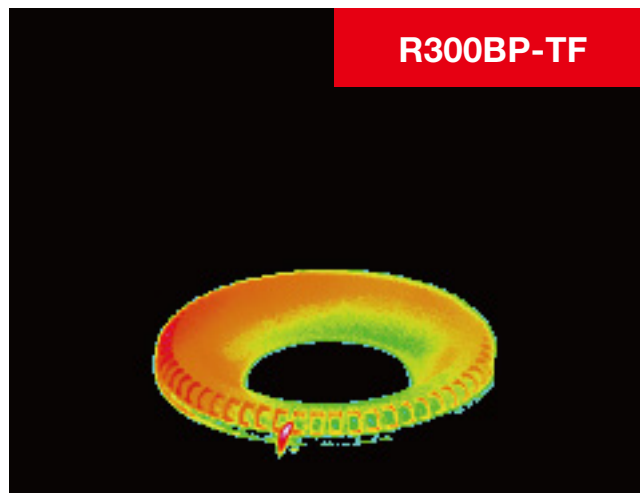

R300BP-TF

By stretching the sensitivity of the “Japanese-made” uncooled detector to the short-wavelength region, it is possible to eliminate the flame influence by using a 3.8μm passing-through-flame filter.

Measuring data in harsh environments exactly and safely

Protection shield included as standard



Movable LCD monitor and View Finder



LCD monitor enable to capture images at various angles

Thermal movie images can be recorded on SD card at max 10Hz and can be analyzed by software later. In this manner, required data can be recorded in a short time.



▶Thermal Images

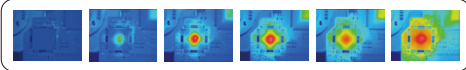

Combination with relay lens^{※1} insertable in the furnace

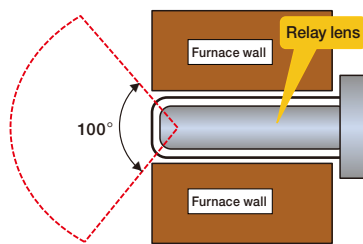

A field of view up to 100° can be covered

※1: Relay lens is custom made for customer

The principle of Through Flame IR image and feature points of R300BP-TF

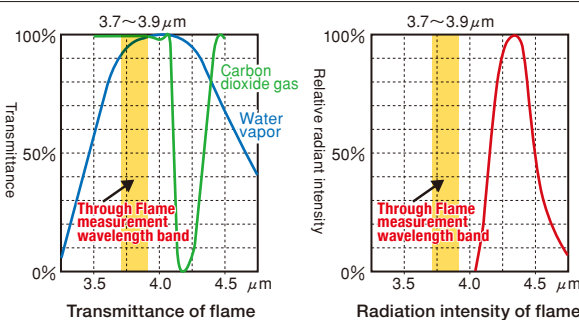

When fuel gas (Hydrocarbon Gas) burns, the infrared energy is radiated from not only flame but also H₂O and CO₂.

For above condition, taking thermal image through flame by infrared thermal imaging camera (IR camera) is required following conditions:

1. Select absorb-less band of wavelength by Gas (CO₂ and water vapor) that is generated when fuel gas burns.
2. Select wavelength band as far away from Flame Infrared Energy radiant intensity wave length as possible.
3. Use Infrared Detector which has sensitivity with above both conditions.

Therefore, the suitable wavelength band for taking thermal image passing through flame is 3.8μm wavelength band.

Generally, this wavelength band is detected by cooled type infrared detector, however, this type IR camera is very expensive and its cooler requires maintenance at constant time usage.

Avio achieved success to stretching sensitivity to short-wavelength band by "Japanese-made" Uncooled type infrared detector. Herewith, we realized to reducing-cost and maintenance-free of R300BP-TF.

*Note: Depending on combustion gas kinds, R300BP-TF has possibility that cannot eliminate flame, and it influence to measuring result. We recommend to test by Demo-Unit before purchasing.

Primary Specifications and Features

Item	R300BP-TF
Infrared Detector	Uncooled Focal Plane Array (Microbolometer)
Spectral Range	3.7 to 3.9μm
Measuring Range	400°C to 1500°C
Sensitivity (NETD)	4°C at 400°C (with S/N improvement)
Accuracy	±4°C
Frame Rate	60Hz
Detector Pixels	320 (H) × 240 (V) pixels
Recording Pixels	Standard mode : 320 (H) × 240 (V) Super Resolution mode : 640 (H) × 480 (V) ^{*1}
Field of View	22° (H) × 17° (V) (with Standard Lens)
Spatial Resolution	Standard mode : 1.2 mrad Super Resolution mode : 0.8 mrad equivalent ^{*2}
Focal Distance	50cm to infinity (with Standard Lens)
Auto Functions	Auto Scale, Auto Focus, Full Auto
Image Quality Improvement	Averaging (with ghost rejection), Edge Enhancement
Point Temperature	10 Movable Points, Temperature search : MAX/MIN x 1 each, Delta T
Temperature Display in Assigned Region	MAX, MIN and AVG in Box (for up to 5 Boxes)
Line Profile	Horizontal, Vertical, Horizontal & Vertical
Alarm function	Alarm Display, Alarm Sound, Color Alarm, Alarm Recording, Alarm Signal Output
Temperature Correction Function	Emissivity, Environment/Background, NUC
Storage Device	SD card, Conforms to SDHC
Data Storage	Still Image : JPEG with temperature data with Visible Image
Interval Recording	3 sec to 60 min interval, with Visible image
Movie Recording	Max. 10fps in SD Card
Voice Recording	30sec Recording, replay per a Thermal image
Interface	USB2.0, Video Output, Alarm Output, External Trigger Input
Display	3.5" LCD Monitor (with tilt and brightness adjustment), Color View Finder (with tilt adjustment)
Operating temperature/ Humidity	0°C to 40°C, 90%RH (non-condensing)
Storage temperature/ Humidity	-40°C to 70°C, 90%RH (non-condensing)
Vibration / Shock	29.4m/sec ² (3G), 294m/sec ² (30G)
EMC	Conforms to CE regulations (Class A)
Dust & Splash proof	Protection class IP54 equivalent
Battery Operation	2hours (Typ.), 4hours with optional "Portable Power"
AC Power	100V - 220V AC, 50/60Hz
Dimensions	Approx. H121mm × W105mm × D195mm (excluding Protection)
Weight	Approx. 1.5kg (including Battery Pack)
Standard Software	InfReC Analyzer NS9500 Professional

*1 Still Image Only

*2 This increased resolution results from detecting characteristic within all frames acquired by the SR process and removing such effects as those caused by hand vibration.

Dimensions (Including Protection Shield)

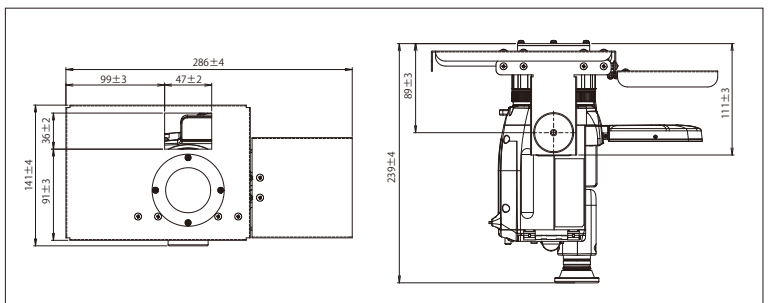

NIPPON AVIONICS CO., LTD.

Thermal Imaging Division

1-5, Nishi-Gotanda 8-chome, Shinagawa-ku,
Tokyo 141-0031 Japan

Phone : +81-3-5436-1614

Fax : +81-3-5436-1395

E-mail : product-irc-e@ml.avio.co.jp

<http://www.avio.co.jp/english/>



WARNINGS & CAUTIONS

- Before using this product, please carefully read the provided Operation Manual "WARNINGS" & "CAUTIONS" section to ensure proper operation.
- Please do not place the product in high temperature, high humidity or high inert gas environments.

Distributor: